

Young Drivers: What do we know, what are we learning?

Robert Foss

University of North Carolina at Chapel Hill

Governor's Highway Safety Association
Annual Meeting
Scottsdale AZ

September 8 , 2008



Overview

- Background
- Recent research findings
- Research under way
- Implications



MV Child Crash Injuries by Age – U.S.

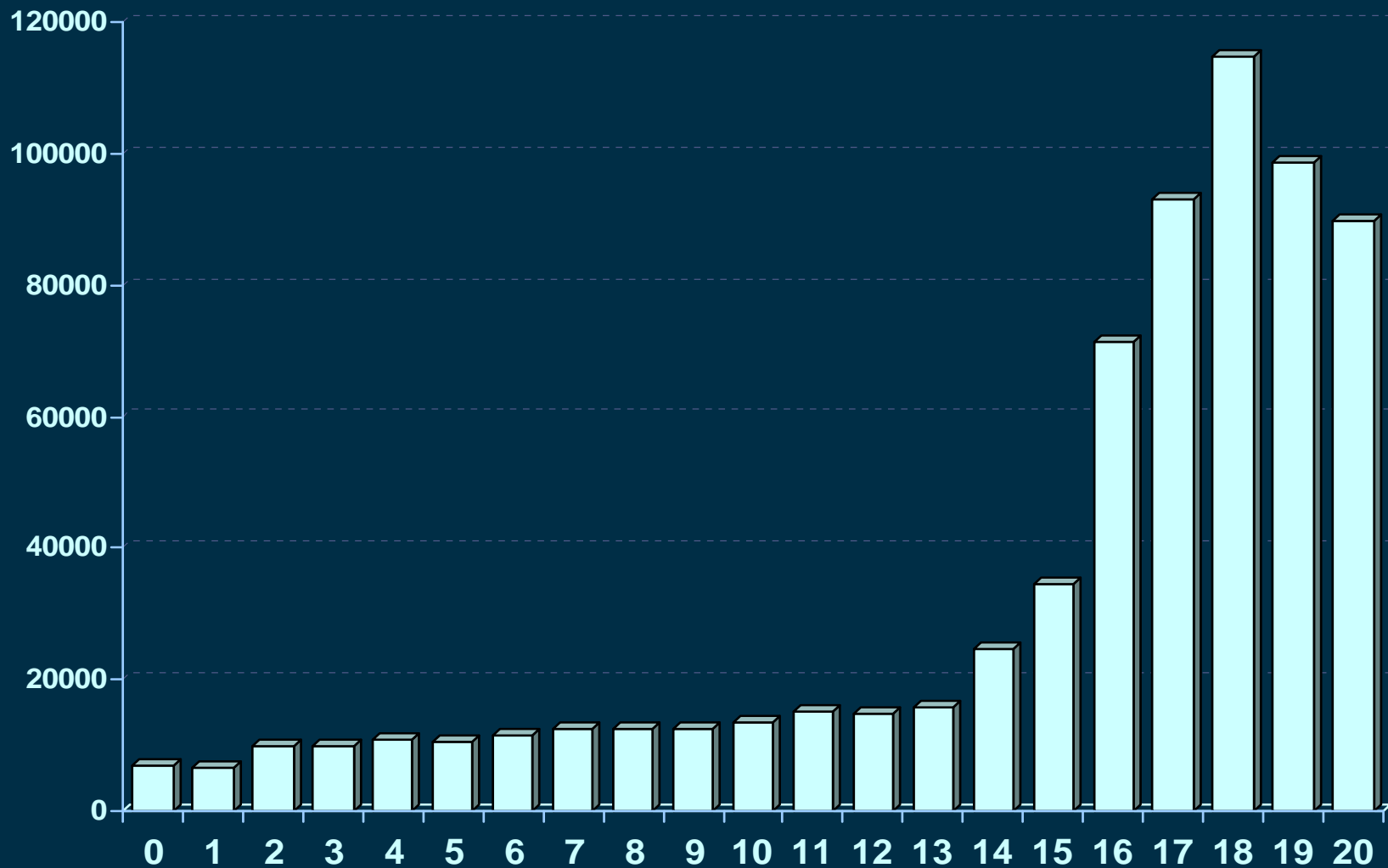

Age

CDC WISQARS: 2006



Understanding Human Behavior

- Not “Rocket Science”
... it's harder

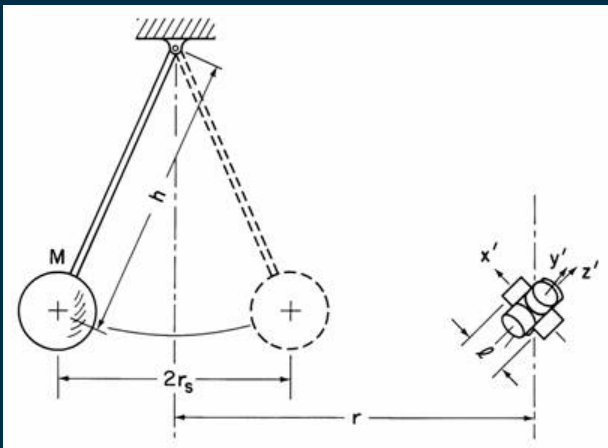



"I can calculate the motions of the heavenly bodies but not the madness of the people"

- *Sir Isaac Newton*

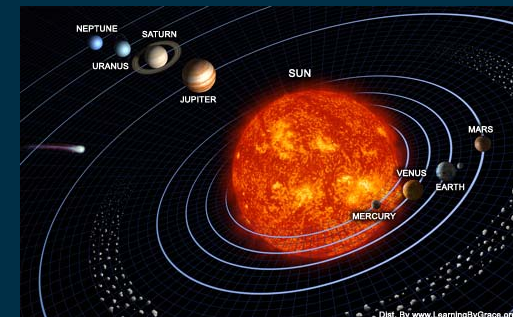
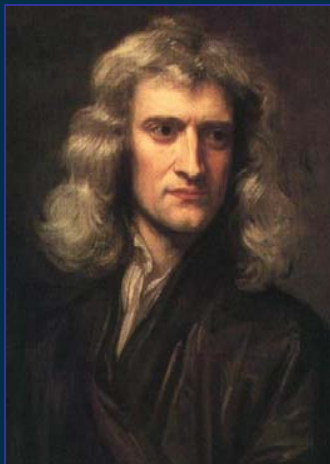

Dist. By www.LearningByGrace.org



Transition to driving

- Driving is complex behavior
 - Physical
 - Cognitive
 - Social
 - Intuitive, non-conscious
- Learning complex skills
 - Mentoring & experiential learning



Experiential learning (pre-GDL)

% Crashing by months licensed

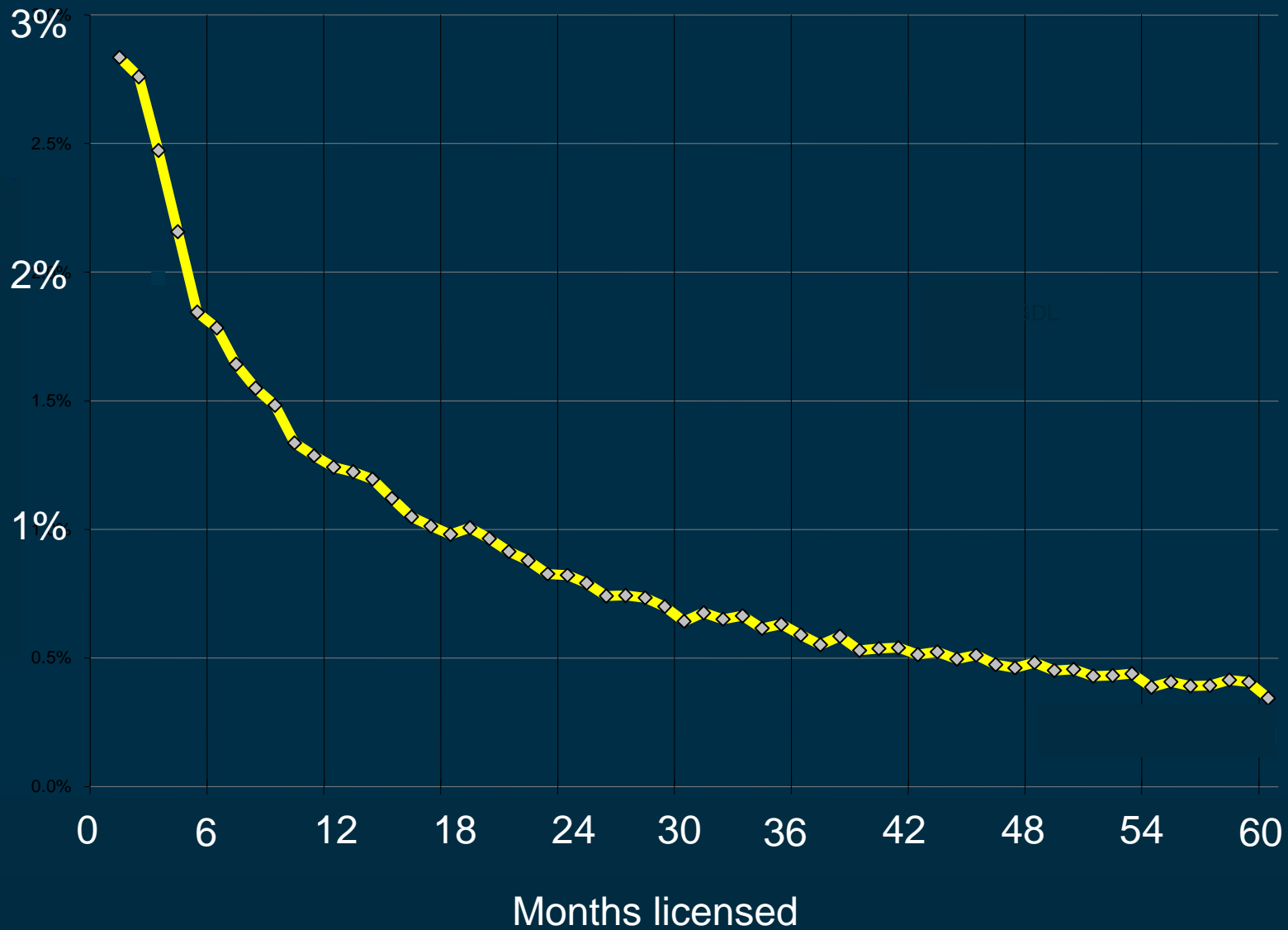



Recent research

- Main action: GDL & cell phones
- Graduated Driver Licensing
 - Effects larger than latest claims
 - Night restriction works (time matters)
 - Passenger restriction works
- Cell phone restrictions



Cell Phone Subscribers

In millions, 2000-2007

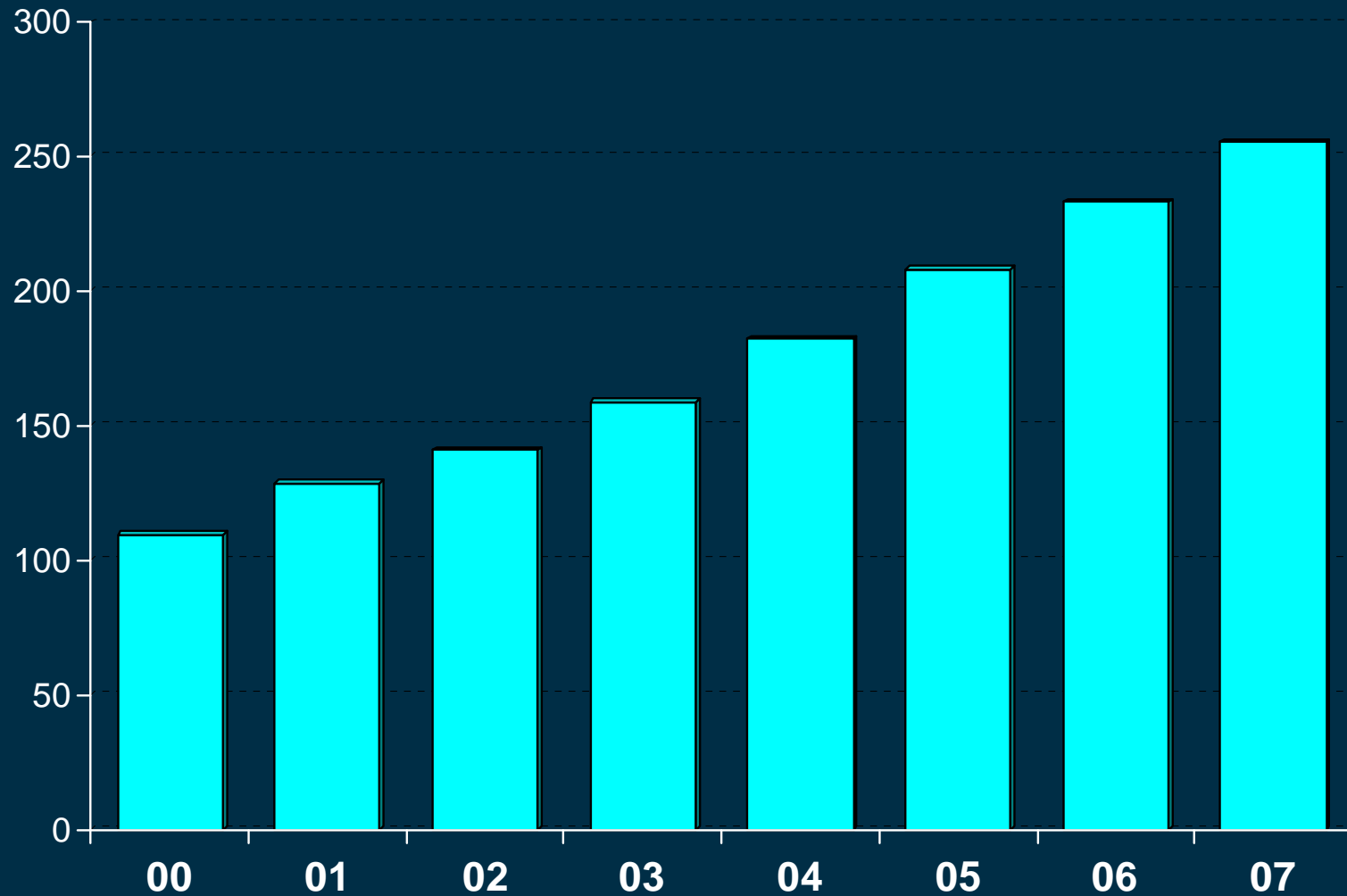

Source: CTIA



Cell Phone Laws – Teens

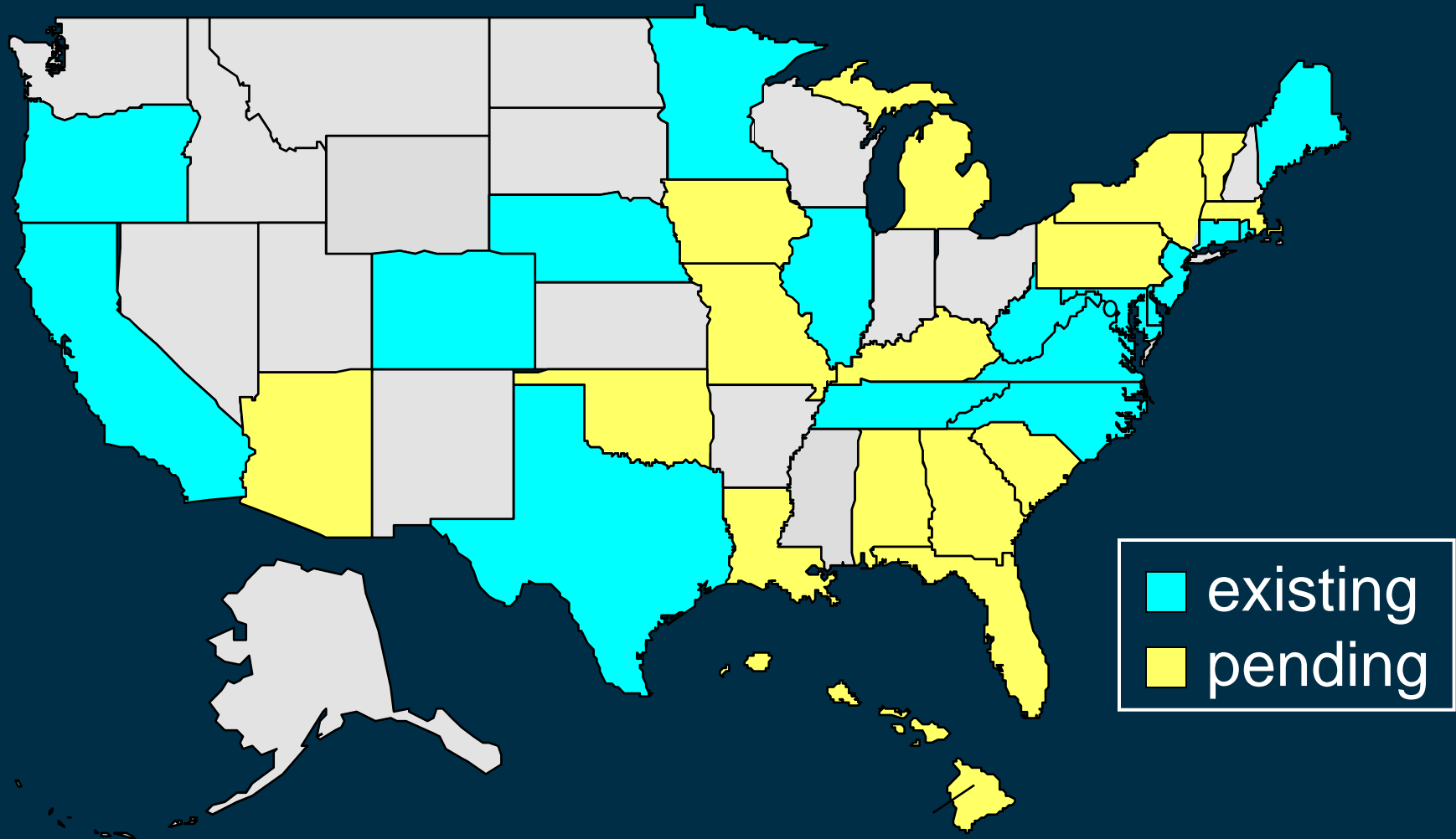



NC teen driver cell phone law

- Pre- / post-law observations
- High schools
- North Carolina & South Carolina
- 12,565 teen drivers observed in NC
- 3,118 in SC

- Pre/post interviews
- 400 pairs of parents & teens
- NC only



Observed Teen Driver Cell Phone Use

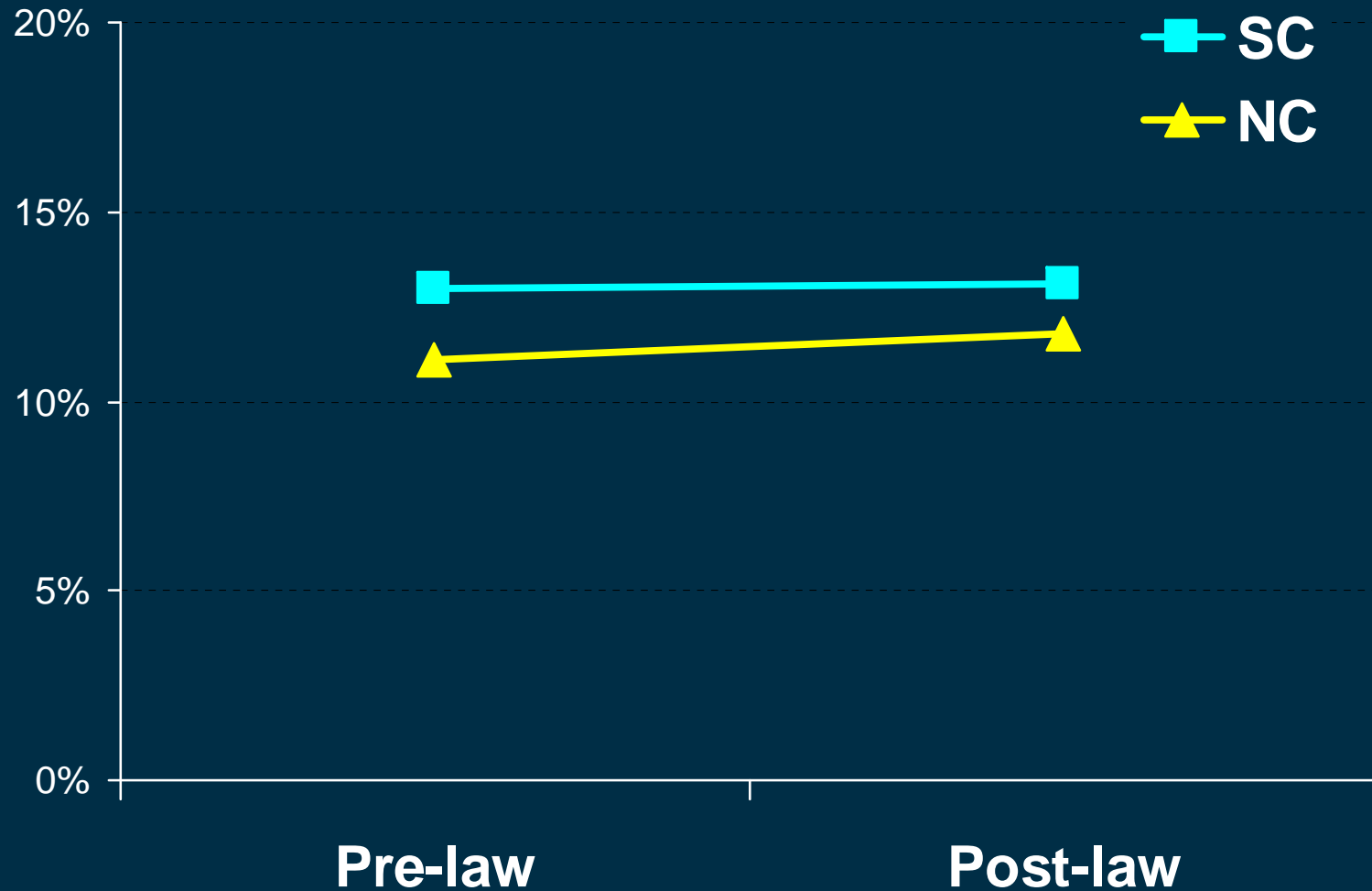



Observed Teen Driver Cell Phone Use

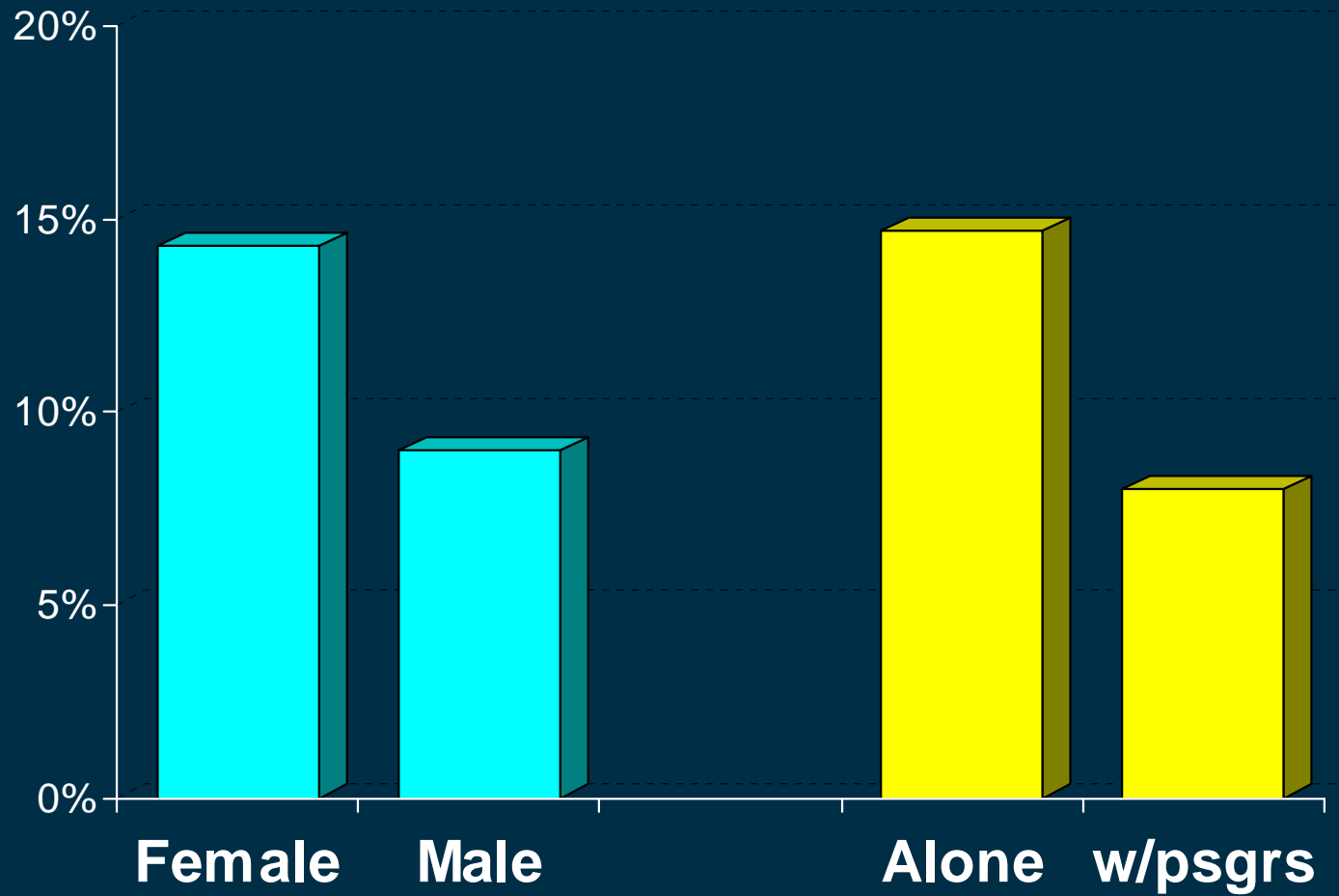



Awareness of the Restriction

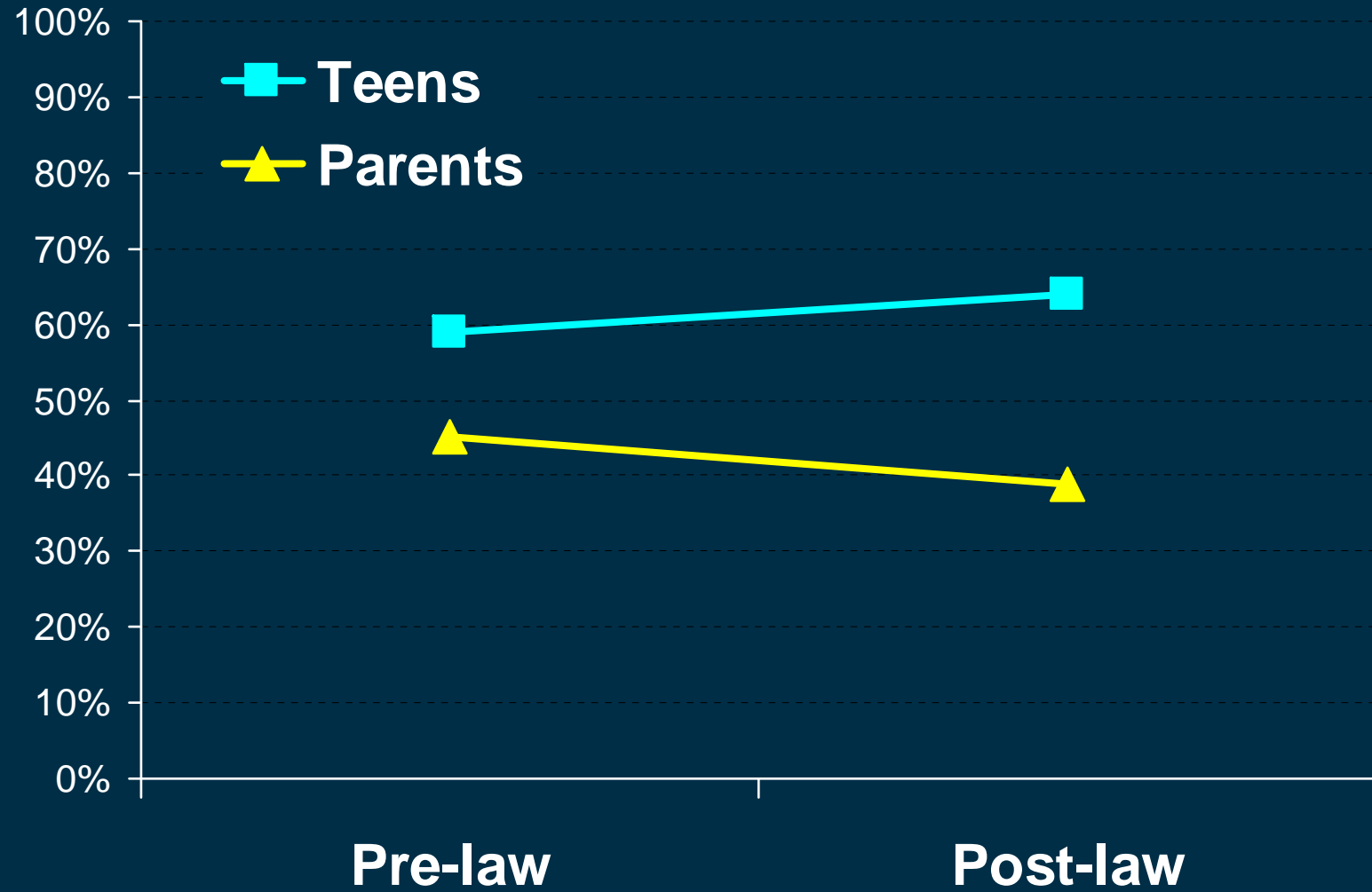



Parent Approval of the Restriction (post-law)

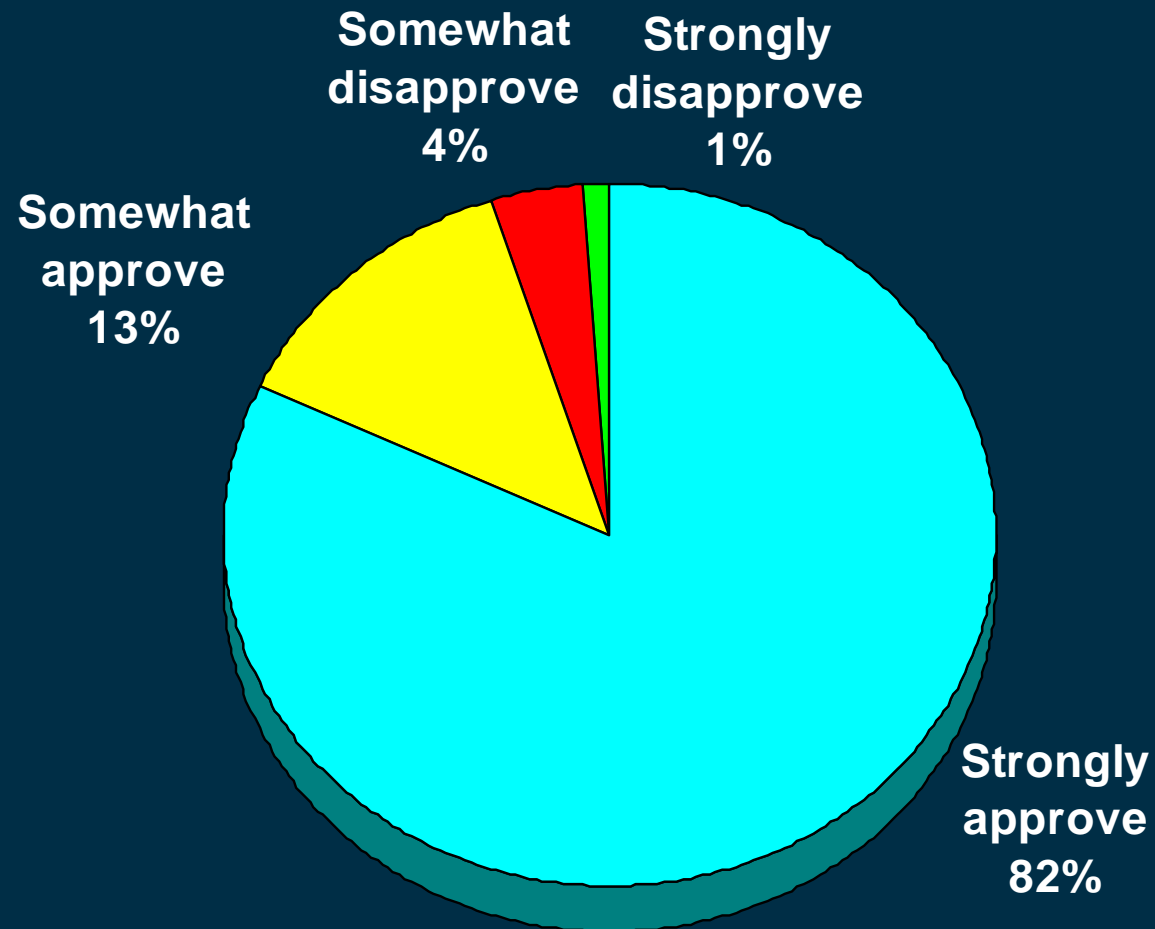



Teen Approval of the Restriction (post-law)

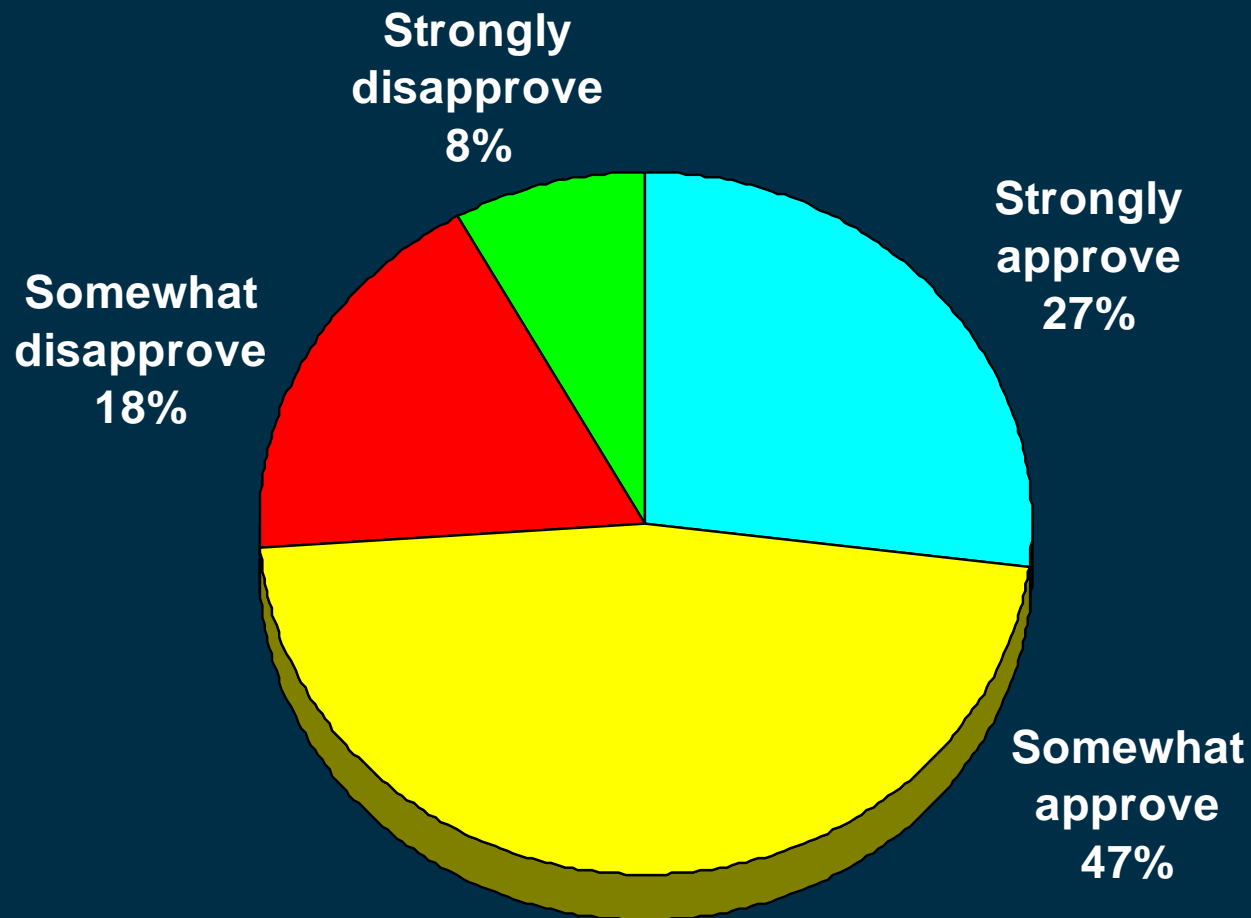



Teen Perceived Enforcement of Restriction (post-law)

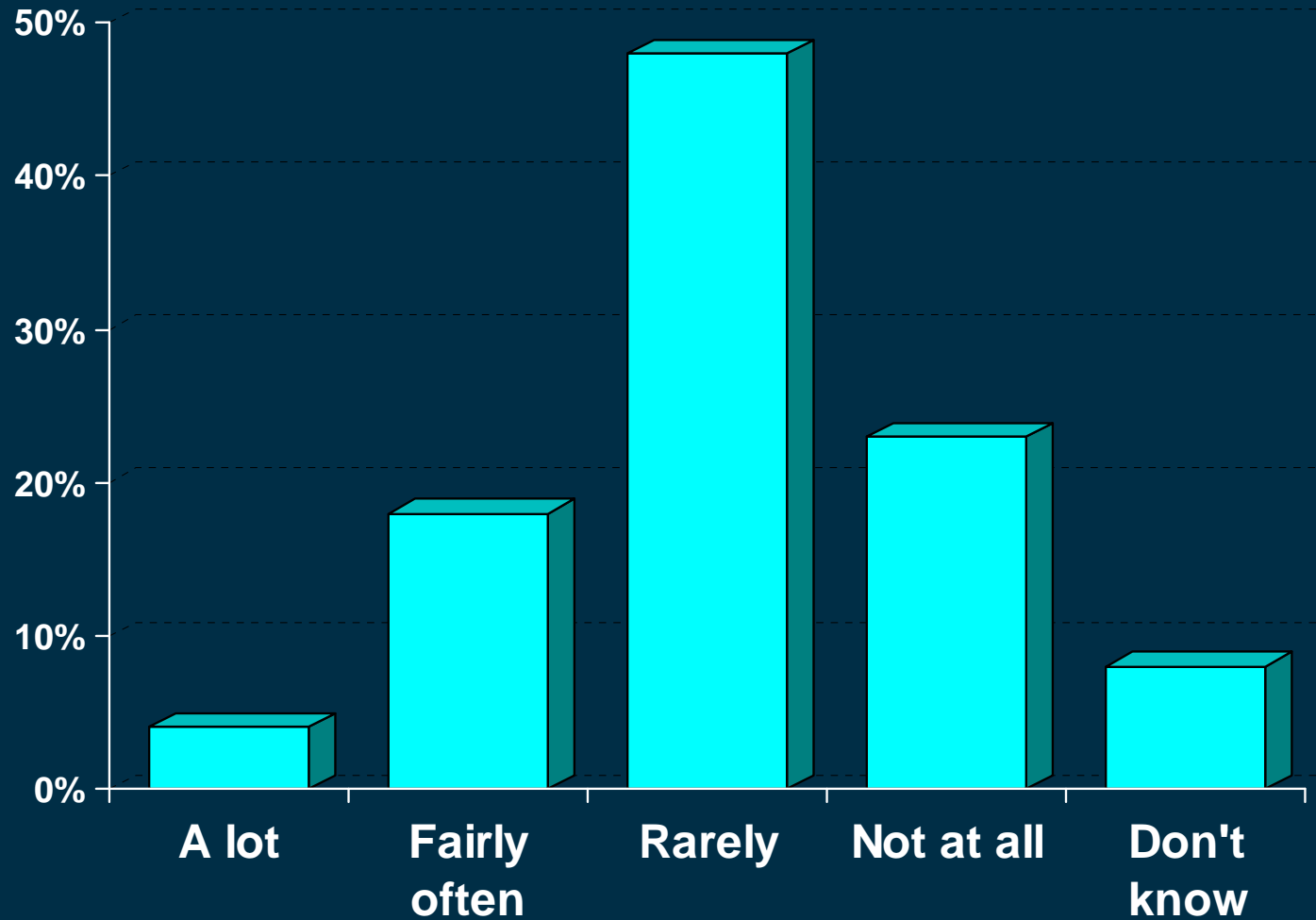



Research on-going: Promising ideas

- **Assisting parents:**
 - **More effective supervision**
 - During learner period
 - **Better monitoring of teen driving**
 - Human, not merely technology



Parental supervision complexities

- Observed instances of parent-teen communication
 - Ships passing in the night
 - Parent conveys “gist” understanding
 - Teen speaks of rational processing
 - Both are correct!



Parental monitoring

- Communication
 - Complex & imperfect
 - Parent-teen "disconnect"



What probably don't work - examples

- “Messages,” slogans, bumper stickers
- Fear appeals (e.g., Grim Reaper)
- Tweaking Driver Ed
- Advanced skill training
- Increasing punishment
- Research needed – not under way



Human behavior ... hard to turn!





Resources

Goodwin AH, Foss RD, Mayhew D, & Sohn J (2007). ***A guide for reducing collisions involving young drivers.*** Washington, DC: Transportation Research Board.

Goodwin AH, Hall WL, Raborn JC, Thomas LJ, Masten SV, Tucker ME (2008). ***Countermeasures that work.*** Washington, DC: National Highway Traffic Safety Administration.